

PORT INFORMATION

MUCURIBE TERMINAL



Review	Changes	Date	Preparation	Approval
0	Initial	06/2009	Lizanias / Tavares	Josenildo
1	Revision 1	04/2010	Tavares / Josenildo	Francisco
2	Revision 2	06/2011	Tavares	Francisco
3	Revision 3	12/2018	Tavares / Neto Saraiva	Allan
4	Revision 4	07/2021	Michele	Allan
5	Revision 4	12/2022	Santoro	Allan

CONTENTS

1	INTRODUCTION	4
2	DEFINITIONS	4
3	REFERENCE OF NAUTICAL CHARTS AND DOCUMENTS	5
4	DOCUMENTS AND EXCHANGE OF INFORMATION	6
5	DESCRIPTIONS OF PORT AND ANCHORAGE	7
	5.1 General Description	7
	5.2 Location	7
	5.3 Terminal Approaches	8
	5.4 Maneuvering Basin	10
	5.5 Meteorological Conditions	11
6	DESCRIPTION OF TERMINAL	13
	6.1 General Description	13
	6.2 Physical Details of Berths	13
	6.3 Mooring Arrangements	14
	6.4 Characteristics of the berth for Loading, Unloading and supplying	14
	6.5 Management and Control	14
	6.6 Main Risks	15
7	PROCEDURES	15
	7.1 Before Arrival	15
	7.2 Arrivals	16
	7.3 Mooring	16
	7.4 Before Cargo Transfer	16
	7.5 Transferring Cargo	17
	7.6 Measuring Cargo and Documentation	18
	7.7 Unmooring and Departure	18
	7.8 Compliance with ISPS Code	18
	7.9 Drug and Alcohol Policy	18
8	PORT OR ANCHORAGE ORGANIZATION	19
	8.1 Port Control	19
	8.2 Maritime Authority	19
	8.3 Pilotage	19
	8.4 Tugboats and Other Marine Services	20
9	EMERGENCY AND COMBAT PLANNING	20
	9.1 Emergency Contacts	20
	9.2 Sensitive areas to the Environment	20
	9.3 General Description of the Emergency Response Organization	20
	9.4 Emergency Plans	21
	9.5 Combat and Emergency Public Resources	22
	9.6 Mutual Support Plans	22
	9.7 Combating Oil and Chemical Spills	22
	9.8 Combating Other Large-Scale Emergencies	23

10 CONTACTS	23
10.1 Transpetro Terminal	23
10.2 Port Services	24
10.3 Navigation Agents	24
10.4 Local Authorities	24

ATTACHMENTS

Annex A – Charter including berths and nearby	
Annex B – Aerial photo of the port of Mucuripe (Wharf and Pier)	
Annex C – Diagram with load connections, dimensions and sizes of the flange’s pier and wharfs	
Annex D – Essential Vessel Information for the Terminal	
Annex E – Information to be exchanged before load transfer	
Annex F – Aerial photo with the identifications of the spaces of the port of Mucuripe and adjacencies	
Annex G – Mucuripe Harbor Trail Routes	

1. INTRODUCTION

The Port Information was prepared by TRANSPETRO, responsible for the operation of the *Mucuripe* - CE Terminal. It provides essential information for ships operating in the terminal. This document is also distributed internally within the organization, for port stakeholders, local and national authority.

The operations of ships operating at the Mucuripe Terminal should always be in accordance with the recommendations of the national maritime authority (CPD) standards and recommendations of the conventions of the International Maritime Organization (IMO).

Port Information is available in Portuguese and English versions.

The information contained in this publication is a supplement, never replace or change any type of legislation, instructions, guidance, official national or international publications. Therefore, any item contrary to the above mentioned documents should be disconsider

The Terminal reserves the right to change any of its operational characteristics presented herein, without prior notice.

If incorrect information is found which needs to be updated, please contact:

Mucuripe Terminal Coordination

Address: Praça Amigos da Marinha S/N – Bairro Mucuripe
60.180-422 – Fortaleza – CE
Tel.: 55 85 3957 0005/0006 – 3957 0023
cel 85 – 99659-2467 (Plantão 24Hs)

Petrobras Transporte SA - Transpetro

Address: Av. Presidente Vargas, 328 / 9th floor – Centro
20.091-060 - Rio de Janeiro - RJ
Telephone: (55 21) 3211-9085
Fax: (55 21) 3211-9067

The latest version of this Port Information and the other terminals operated by Transpetro can be obtained from the following address:
www.transpetro.com.br

2. DEFINITIONS

AIS - Automatic Ship Identification System (ISPS Code).

BP (Bollard-Pull) - Longitudinal Static Traction of Tugs (Power).

CDA - . Environmental defense center

COW - Crude Oil Washing (Cleaning of Cargo Tanks with Crude Oil).

CRE - Emergency response center

Draft - Vertical distance in meters marked on the side of the vessels from the waterline to the keel.

Giaont - Group of Inspection and Operational Monitoring of Ships and Terminals.

IMO - International Maritime Organization.

ISGOTT - International Safety Guide for Oil Tankers and Terminals (International Guide for Safe Operations of Tank Ships and Terminals).

ISPS Code - International Ship and Port Facility Security.

PAM - Aid plan mutual

PFSO - Port Facility Security Officer (ISPS Code).

POB - Pilot on Board.

PRE - Emergency Response Plan.

Squat Effect - Increase of the draft of a ship as a result of the increase of the speed of displacement, when sailing in restricted waters.

SOLAS - Safety Of Life At Sea - International Convention on Safe Seas.

SSO - Ship Security Officer (ISPS Code).

STCW - Seafarers Training Certificate and Watchkeeping.

SWL - Safe Working Load.

Syzygy tides- Condition in which the tide reaches the maximum and minimum amplitude, at certain times of the year.

TPB (GT) - Gross Tonnage.

UN-Bunker - Petrobras department that sells fuel (bunker) stored at the Transpetro terminals.

UTC - Universal Time Center.

VHF - Maritime communication system.

VTS - Vessel Traffic Service

3. NAUTICAL CHARTS AND REFERENCE DOCUMENTS

Information regarding the Mucuripe Terminal can be obtained from the publications listed below:

Cards

Area	DHN Charter Number
Near the Terminal of the Pecém and the Port of Mucuripe	710
Port of Mucuripe (Fortaleza)	701
British Admiralty nautical Chart	3957

Other Publications

Type/Subject	Editor / Source
	Brazil (DHN)
Standards and Procedures of the Port Authority	NPCP-CE

Observations and more updated information are publicized in the Notice to Mariners, which can be obtained by Agency or accessed at the site: www.dhn.mar.mil.br

4. DOCUMENTS AND INFORMATION EXCHANGE

The items listed below must be provided by the Terminal or the Ship, as indicated in the table.

Information	Prepared by:			Delivered to:			Comments
	Terminal	Ship	Both	Terminal	Ship	Both	
Prior to Arrival							
Estimate Time of Arrival (ETA) and information about the vessel		X		X			
Essential information about the Terminal	X				X		
Before the Transfer of Cargo or Bunker							
Details on cargo / "slop" / ballast on board		X		X			
Information essential to the operation (<i>complete on site</i>)	X				X		
Ship / Land Safety Checklist			X			X	
During the Transfer of Cargo or Bunker							
Repeat the Ship/Shore Safety Checklist			X			X	
After the transfer of the cargo or bunker, before departure							
Information necessary to untie the ship			X			X	
After untying, on leaving the port							
Information related to the port departure data		X		X			

5 DESCRIPTION OF THE PORT AND ANCHORAGE

5.1 General Description

The Port of Fortaleza, is located of Mucuripe bay, is an artificial terminal administered by [Compainha Docas do Ceará], which is responsible for updating port information. Its main characteristics are:

a) A commercial pier accostable with 20 meters wide and 1,054 meters of extension, with 6 cots of mooring, denominated 101 to 106;

b) A tanker pier consisting of an operating platform with extension of 90 meters with two berths and depth of 13 meters (external berth 202) and 13 meters (internal berth 201), having an access bridge with 853 meters with eleven pipes;

c) Depth along the pier - varying between 3,6 and 13 meters. Depth of berths, maximum gross weight and maximum dimensions of vessels, with annual updates, are disclosed on the website www.docasdoceara.com.br, of the Ceará Dock Company [Companhia Docas do Ceará].

5.2 Location

5.2.1 Coordinates

The Mucuripe Waterway Terminal is located at the following coordinates: latitude 03° 42 ' .63 S and longitude 038° 28 ' , 5 W.

The port and its access are on the nautical chart DHN-701, and the publication NORTH COAST ROUTE [ROTEIRO COSTA NORTE] must also be consulted, as well as observing the information published in the **NOTICICE TO MARINERS** on the site: www.dhn.mar.mil.br.

5.2.2 General Geographic Location

The port area is bounded by the parallel of latitude 03° 42 ' S, coastline and meridians of 038° 27'.5 W and 038° 30 ' W;

5.3 Terminal Approaches

5.3.1 General Description

Special approach precautions and main navigational obstacles are listed in the NORTH COAST ROUTE, edited by DHN, specifically in the paragraph called "hazards" and "restrictions"; as well as a recommendation to intensify vigilance in the twilight: morning and afternoon, due to the heavy traffic of rafts and small boats in the port area, posing a risk to navigation.

5.3.2 Anchorage

The anchoring is only allowed in the areas provided for in the DHN-701 nautical chart, as defined below:

Anchorage	Purpose	Area
No.1	ships with more than 7 meters (22.97 feet) draft	Circle of 0.3 nautical radius, centered on Lat position. 03° 41.74'S and Long. 038°30,31'W
No.2	vessels of more than 2,000 AB, with draft up to 7 meters (22.97 feet)	Circle of 0.3 nautical-mile radius, centered at the latitude position 03° 42 ' , 13 S and longitude 038° 29' , 78 W
No. 3.	vessels from 200 to 2,000 AB	Circle of 0.2 nautical radius, centered on the position of Lat. 03° 42.47's and Long. 038° 29.41'W

No.4	maritime and port support vessels	Circle of 0.055 miles radius, centered on Lat position. 03° 42.80's and long. 038° 28,69'W
NO.5	mechanically propelled fishing vessels	Delimited by coordinates: Lat.03°42,800'S and Long.038° 29,000'W Lat.03° 42,988'S and Long. 038° 28.707'W Lat.03° 43,187'S and Long. 038° 29,032'W Lat.03° 43,000'S and Long. 038° 29,109'W
No 6	mechanically propelled fishing vessels	Delimited by coordinates: Lat.03° 43,000S and long. 038° 29,109'W Lat.03°43,187'S and Long.038° 29,032'W Lat.03° 43,255'S and Long. 038° 29,458'W Lat.03° 43,000'S and Long. 038° 29,458'W
No 7	craft with draft depths greater than 9 meters (29.53 feet)	Circle of 0.5 miles radius, centered on the position of Lat. 03° 39.20'S and Long. 038° 25,00'W

The anchoring in the vicinity of: Gas pipeline and pipelines indicated in DHN 701; and any emergency facility, not scheduled, shall be informed to the Port Authority.

Ships in "Quarantine" must use the anchorage no. 1 and 2, with authorization of the Port Authority.

5.3.3 Navigation aids

The access to the port area limited by the parallel of latitude 03° 42' S and meridians 038° 27.5 W and 038° 30' W. Easily identified on the Radar by the visualization of the breakwaters on the Praia do Futuro and the Titan Lighthouse. Whose extension of the breakwater protects the entrance of the channel to the Pier, as shown on nautical chart DHN-701; and the publication ROTEIRO COSTA NORTE should also be consulted, as well as observe the information posted on the Navigational Notices on the site: www.dhn.mar.mil.br

5.3.4 Port Limites

The port area is limited by the parallel of latitude 03° 42 ' S, coastline and meridians of 38° 27.5 W and 038° 30 ' W; considering the crossing of the Titan faroleta, before the entrance of the first pair of buoys of the Canal to access the port area.

5.3.5 Port Control or VTS

The traffic control of the port done by "Berthing", which is managed by Ceará Dock Company, on a 24hr shift, attending ships entering or leaving through channel 16 of the maritime VHF.

To attend port operations, the operation of the Port of Fortaleza is continuous, 24 hours a day, including Saturdays, Sundays and holidays.

5.3.6 Pilotage

In or outside the port area, pilotage is mandatory for all vessels that are destined to the waterway terminal of Mucuripe. Request the pilotage through the vessel's agent 24 hours before arrival. Also, order them, in a timely manner, through channel 10 or 16 in VHF maritime.

The boarding point and landing of the Lat practical. 03° 39,540's and Long. 038° 29,230'W

Pilotage maintains a traffic control post in the port, with permanent listening on channel 10 and 16 of the VHF marine.

Vessels shall be sufficiently level-weighted, with a draft suitable to the limit of the port and properly equipped for mooring, navigation and accessories.

During unloading, the pilotage scheduled through the Agent of the vessel, by means of the forecast of completion of the operation provided by the ship and time of release of the documentation of the load.

Captain is responsible for the safety of the maneuvers and it is responsible upon him to provide all information to the Pilot about the peculiarities of the ship. Such as: any difficulties, machinery failures, breakdowns in critical equipment, or any item that could endanger the mooring, passage of cables, connection of the hoses and the normal operation of loading or unloading the ship during stay in the terminal.

5.3.7 Port Resources and Services

The Companhia Docas has the resources to provide the following services:

- Supply of diesel oil, with a maximum flow rate of 500ton / l reservoir (cap) 4,000 tons;
- Supply of fuel oil, with a maximum flow rate of 50 ton / l tank (cap) 1,500 tons;
- Water supply, with a maximum flow rate of 270 tons/ h;

5.3.8 Navigation Risks

Vessels in channel approaching should pay attention to sandbars north-west of the channel entrance and identify jetties for ships from the south and the Titan lighthouse from the north, the best positioning reference can be obtained with the use of navigation indexed by the Titan lighthouse, which has the following characteristics: green flash 3sec 15m 10M. Particular attention should be paid to the ship's comes from Southwest to the risk of approaching Recife da Velha and Pedras do Justin, where navigation risks is marked by blind red buoys.

5.3.9 General Restrictions

The traffic in the port complies with current legislation, as well as the rules in the international conventions ratified by Brazil, in addition to the norms established by the Brazilian Navy and those issued by the Port Administration.

Vessels navigate into the channel, should keep one of the anchor, ready to let go, above the waterline in case of emergency.

Only small boats, authorized by the Brazilian Navy, can provide services between ships , onshore support, transportation of people and material. The embarkation and disembarkation can only be done in one of the tax points, in compliance with the regulations of the National Agency of Sanitary Surveillance (ANVISA), Federal Customs and Federal Police.

Is prohibited, for the berthed ship to make a repair that makes it impossible to maneuver, except in special circumstances and after obtaining authorization of the Port Management, Terminal and Maritime Authority.

Treatment and painting decks and topsides are allowed, and the ship must be provided the necessary measures to prevent the fall of persons and materials at sea. Planks and canoes may be

lowered without prior Brazilian Navy license, which, however, must be collected at the end of the day or at sunset.

The movement of ships, unable to maneuver with their own resources, from or to the anchorage area must be performed using special device such as tugboats, appropriate to unpowered towing situations, always with the pilot embarked. These maneuvers shall not be carried out at low tide for vessels of draft greater than 5 meters.

5.4 Maneuvering basin

The entrance bar is 100 meters wide and has a depth of 11 meters.

The access channel has about 3,500 meters in length by 160 meters wide and depth of 12 meters, rectilinearly, leading directly to a faction area and basin of evolution.

It has a basin of evolution with 610 meters wide and depth ranging from 13.5 to 14 meters, protected by a jetty, located in the northern part of the pier, with 1,910 meters in length. There are still 7 facing areas with good safety conditions.

In the basin of evolution and in the access channel to the Port of Fortaleza, the recommended minimum speed is the one that allows the ship to be governed safely. The maximum speed allowed is 10 knots.

5.4.1 Mooring Aid

For mooring and port facilities, Companhia Docas do Ceara provides tugboats in accordance with the rules of the Brazilian Navy and may be requested by Maritime Agents, at any time, for any needs.

5.4.2 Depth Control

RECOMMENDED MAXIMUM AMOUNTS (CMR), ACCORDING TO CHAPTER 5 - ITEM 0501 OF THE Brazilian Navy regulation

a) Port of Fortaleza (Enseada do Mucuripe) - Channel depth its between 13,5 and 14 meters (m); according NPCP by Brazilian Navy.

:

5.4.3 Maximum Dimensions

Porto of Mucuripe (Information obtained from the Brazilian Navy)

Berth	Bollards	Draft (m)	TPB (t)	LOA(m)	Breadth (m)
102 (commercial wharf)	8 to 15	5,0 a 7,0	50.000	232	30
103 (commercial wharf)	16 to 22	10,30	50.000	232	30
104 (commercial wharf)	23 to 30	11,0	60.000	232	30
105 (commercial wharf)	31 to 38	11,0	60.000	232	30
106 (Passenger Term.)	39 to 51	9,0	50.000	239	35
201 (internal pier)	1 to 5	10,40	50.000	222	33
202 (external pier)	1 to 5	10,40	60.000	222	33

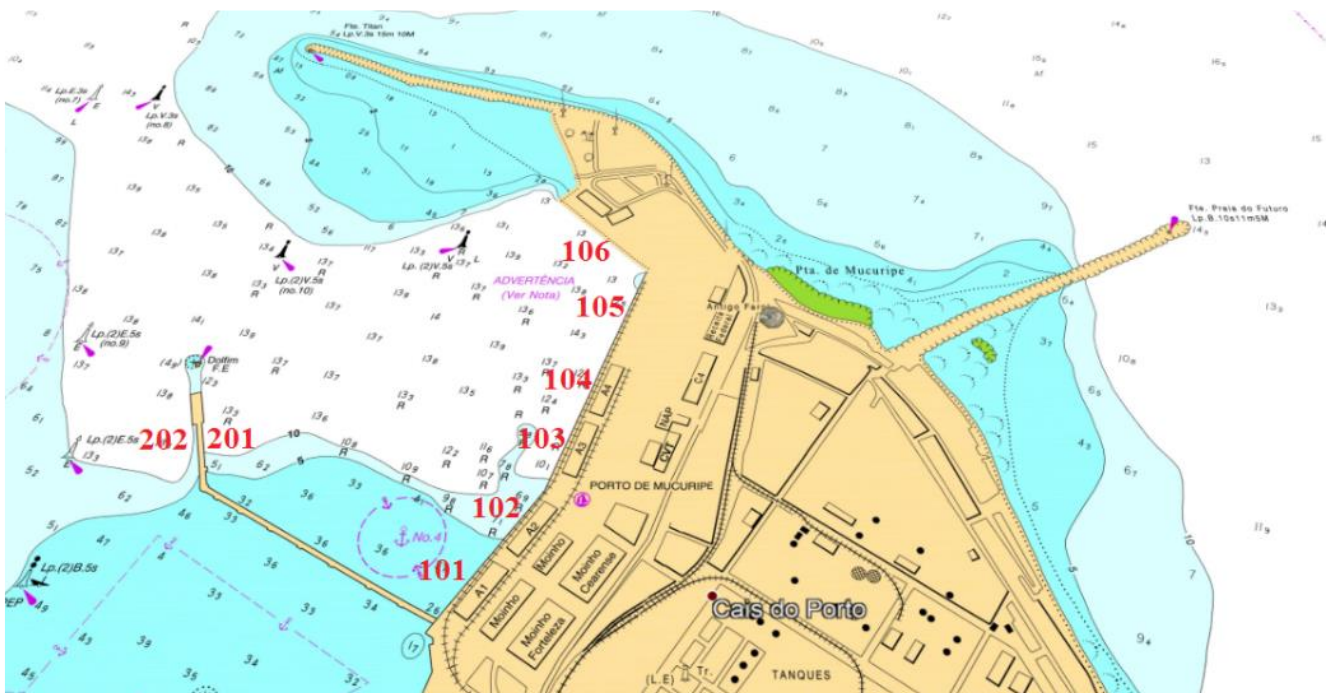

5.5 Meteorological conditions

5.5. Wind Limits	5.5.2 Swell limits
35 knots stop cargo transfer	1.5 meters stop cargo transfer
40 knots Disconnect	2.0 meters Disconnect
45 Knots unberth	2.5 meters unberth

5.5.3 Precipitation and Humidity

The rainy regime of the region can be defined as the tropical type with concentrated rain station in four consecutive months and a dry period at approximately eight months. Preferably, the station rainy occurs in the months of February to May, with a greater precipitation in the month of March, decreasing progressively in the remainder of the year, with values minimum between the months of September and November.

This variation of precipitation in our State is controlled by the intertropical convergence zone which, depending on its position and time of permanence, can generate years with more or less rainfall.

Humidity has a pattern of variation similar to precipitation, with a maximum in March (83%) and a minimum in September (74%).

Sunshine average annual is 3,000 hours, which is equivalent to an average solar incidence of 8 hours / day. In the rainy period this incidence goes to 6 hours / day on average.

5.5.4 Atmospheric pressure

Minimum: 1.0074 bar;
 Average: 1.0087 bar;
 Maximum: 1.0100 bar.

5.5.5 Visibility

Normally considered good to excellent, it can be reduced in the rainy season. The months with the highest percentage of cloud cover are from January to June, but do not prevent or impair the entrances, mooring and unloading of the ships, nor the loading and unloading operations.

5.5.6 Currents of the Tide

The current data of the channel of Fortaleza port were obtained through study made after last dredging in 2011.

Of the measurements was observed a predominant direction between 270 ° and 315 ° nm, with speeds ranging mainly between 0 and 20 cm.s⁻¹, which corresponds to more than 80% of the percentage of speed values, as maximum value 100 cm.s⁻¹, and minimum of 0 cm.s⁻¹, with an average of 16.6 cm.s⁻¹.

From the vertical current spectrum analysis, it is possible to identify that in general, in the middle and bottom layers the speed has intensity ranging from 10 to 30 cm.s⁻¹, and surface This speed can reach up to 100 cm.s⁻¹.

A tide speed variation while increasing depth.

The wind causes the speed of the current in the closest layers of the surface (and which are influenced by this) have superior absolute values to the middle of the fund.

As already mentioned the current that is situated closer to the surface seems suffer not only the influence of the current, visible in the semidiurnal of the tide, but also a behavior with the same frequency standard of the winds. In the period of sampling, months of March and April, is the period that the winds present the lower intensities, the winds are more intense between August and October. In this way, the importance of the wind as a dynamic agent should be consideration, since the shear tension of the wind is of great importance for the variability of the velocity of the surface current.

5.5.7 Tide

The cost of Ceará can be classified as a meso-tide environment. The regime dominant is semidiurnal with two low seas and two prayers in 24 hours and 50 '(a full tide cycle). According to data obtained for the Port of Mucuripe(Source: InPH), tidal levels range from 0.5 meter to 3.87 meters, with 3.3-meter amplitudes during syzygies and 1.2 meters during quadrants.

5.5.8 Measurements

The terminal does not have wind sensor and current. When vessels approach to berth this information may be made available to the vessel by the pilotage station on VHF channel 10 or by the website: www.cearapilots.com.br and Brazilian Navy [Capitania dos Portos do Ceara], with weather forecast on the site: www.mar.mil.cpce. One can also obtain a more anticipated forecast by the website of FUNCEME - (www.funceme.br), a portal of the Government which provides a daily update of the meteorological bulletins. Daily, Terminal sends to ships a Meteorological bulletin.

6. DESCRIPTION OF TERMINAL

6.1 General Description

The Mucuripe Terminal is made up of the Petroleum Pier and Pier of the Companhia Docas do Ceará (CDC). Considered a small terminal and the main operations in the Pier are the filling, loading and unloading of: LPG, oil and oil products. Have two sides for berthing, denominated External and Internal berth. Pier is located at a distance of 1000m from the Lubricants and Petroleum Derivatives Business Unit of the Northeast - LUBNOR, responsible for the tanking of products operated at Pier.

Companhia Docas do Ceará, there are diesel and fuel oil supply networks installed which are operated by Transpetro as shown in the diagram in Annex III.

6.2 Physical Details of Berths

Table that indicates, among other relevant details of the location, the name / number of the pier, type, length, depth, tidal elevation, maximum length, displacement, berth.

Oil Tanker Pier				Mucuripe waterport terminal					
Berth Name	Type (example)	Length From the berth (meters)	Depth (meters)	Tide (meters)		Berth (maximum m)	Length of the Vessel (maximum m)	Products Handled	Notes (Indicate any berthing aid for the 2 berths)
				Syzygy	Dry				
External	Pier;	222	12.00	14.00	11.0	33.0	222	Crude Oil, Derivatives, alcohol and LPG	Body Parallel: Min 50m and Max 110m,
Internal	Pier;	222	11.00	13.00	10.0	33.0	222	Crude Oil, Derivatives, alcohol and LPG	Freeboard: Min 6m and Max 15m

6.3 Mooring Arrangements

Mooring Arrangements														
No. of the Berth <i>(example)</i>	Requires practice for maneuvers	Example of Embarking Port: TPB (maximum)	No. & BP of Tugboats				Approach		Mooring Points		Mooring lines			
			Mooring		Unmooring		Speed (maximum)	Angle (maximum)	Bits	Hooks	Head line	Spring lines fore and aft	Stern lines	Brest line
			No.	BP	No.	BP								
201	yes	50,000	3	120 t	3	120 t	0,2m/s	nil	100 t	nil	4	2	4	Captain decision
202	yes	60,000	3	150 t	3	150 t	0,2m/s	nil	100 t	nil	4	2	4	2 fwd station

Considering the maximum condition (loading or unloading) for defining the number of tugs and the required "Bollard Pull", use the table above validated by NPCP-CE.

6.4 Characteristics of the berth for Loading, Unloading and Supplying.

The table below indicates by pipeline: the products moved the available hoses / arms, the connections, reductions and details of the flange, temperature limits, flow rates and maximum loading / discharge pressures for both cribs.

Identification of duct	Diameter of the duct	Types of oil transported	Maximum operating pressure	Maximum operating temperature	Maximum operating flow
Petroleum	18"	Petroleum / Nafta	7 kgf / cm ²	90° C	1000 m3/h
Fuel oil	16"	Fuel Oils / MF	7 kgf / cm ²	90° C	300 m3/h
Marine Fuel (MF)	6" and 8"	VLSFO	5 kgf / cm ²	90° C	150 m3/h
Diesel / QAV	12"	QAV	7 kgf / cm ²	Ambient	750 m3/h
Gasoline /Alcohol	12"	Gasoline / Alcohol	7 kgf / cm ²	Ambient	750 m3/h
Diesel S10	12"	Diesel S10	7 kgf / cm ²	Ambient	750 m3/h
Maritime Gas Oil(MGO)	6"	Maritime Gas Oil	5 kgf / cm ²	Ambient	150 m3/h
LPG	10"	LPG	15 kgf/cm ²	38° C	400 m3/h
NH-140	10"	NH-140	7 kgf / cm ²	Ambient	280 m3/h
NH-20	8"	NH-20	7 kgf / cm ²	Ambient	350 m3/h
NH-400	8"	NH-400	7 kgf / cm ²	Ambient	200 m3/h
Isovolt	8"	Isovolt / NH-10	7 kgf / cm ²	Environment	350 m3/h

6.5 Management and Control

The Terminal has an Operational Monitoring and check system that verifies and updates through Inspection and visits to the ship before start operation.

Approval in ISGOTT 6 Inspection checklist and definition of the voice communication system (radio transceiver and / or telephones);

Measurement of the tanks involved and programmed for the operation, considering vessel measurements and Load / Discharge Plan, presented at the initial meeting.

Information to those involved conditions established for the movements, such as pumps used, expected flow rate, operating temperature in case of heated or refrigerated products and destination of the tank interfaces;

Perform product flow alignment, enable alignment, and adjust supervisory alarms;

Formalizes the Ready to Operate;

It informs the parties involved of the start of the operation;

Throughout the operation, the parties involved must be informed at least half an hour in advance of the following events:

Start and End of operation;

Tank exchange;

Change of Pressure and Pressure, that destabilize the operation;

Alignment changes.

Change in the quality or quantity of the product;

Change of dispatching or receiving tank;

Change of atmospheric conditions (wind, sea, visibility and rainfall);

Any change to the Initial Plan provided for the Operation;

6.6 Main Risks

All vessels berthed at the terminal should maintain continuous supervision during operations with oil or oil derivatives and liquefied gas. Statistics show that most spills and accidents occur during the loading or unloading period. Therefore, there must be monitoring by qualified crewmembers familiar with the maneuvers so that they can quickly interrupt the operation in the event of an accident or breakdown of the equipment. In the same way that the terminals must maintain operators and safety inspectors so that they can stop the operation immediately in case of product spillage or leakage.

Special attention should to be given the mooring spies when the Swell incidence and strong winds mainly in the months of November to April, increasing a risk to the safety of the mooring.

Crewmembers should be aware of the possibility of unlawful acts such as armed robbery and robbery on board vessels when they are anchored or moored; the service personnel on the ship shall maintain vigilance by avoiding the approach of small vessels to the shipboard.

During loading or unloading of flammable or explosive cargo, the vessel shall the Bravo flag in day and **light up** a red light at night, both on the main mast.

7. PROCEDURES

7.1 Before Arrive

7.1.1 The Terminal send by ships e-mail this port information and reserves the right to refuse mooring or operation of any vessel considered unsuitable or that does not meet the conditions of security, mooring or other circumstance that may create a risk to the Terminal, and this includes personal conduct, equipment operation and risk to the environment.

7.1.2 Onboard repairs and washing of cargo tanks should be carried out, preferably on the road or in the area of the deck. In order to carry out these services with the moored ship, prior evaluation and authorization of the Terminal is mandatory. If crude oil tanks are scheduled to be cleaned, the Terminal should be informed together with the ETA and the ship will have to comply with all ISGOTT procedures relating to the COW operation.

7.1.3 The ships bound for the Mucuripe terminal must indicate the Arrival Estimate (ETA) at 72, 48, 24 and 4 hours in advance, directly to the respective agent and to the operations sector, by e-mail, telex or telephone. Change or confirmation of the arrival of the ship must be communicated a minimum of 12 hours in advance. The ETA should always be informed by using UTC time.

7.2 Arrival

7.2.1 Requests for bunker supplies are sent to Petrobras' UN-Bunker, through its agent.

7.2.2 Bunker supply requests are sent to Petrobras' UN-Bunker through its agent.

7.2.3 Terminal information for the ship and vice versa are described in Appendices D, E and F, respectively.

7.3 Mooring

7.3.1 Mooring plan is made in common agreement between ship's Captain and, Pilot. Should be adequate for the availability and positioning of the heads in the structure of the Pier as long as you respect a minimum configuration. External Berth must be used 04 four head lines ,02 springs lines in the foward station and 04 stern lines, 02 breast lines and 02 springs lines in the aft station. Internal berth 04 head lines and 02 springs lines on the forward station. Aft station, 04 stern line. 02 breast line according captain decision.

7.3.2 The Terminal does not have an access ladder, but it does provide a safe area in the Deck of the Ship for placing the ship's board, which should be properly positioned, with unobstructed access and with protective nets on the sides and bottom.

7.4 Before Cargo Transfer

7.4.1 The terminal uses hoses to carry out operations formed by an electrically discontinuous line and two electrically continuous.

7.4.2 The resources required for connection are agreed upon the first contact of the vessel with the terminal during the initial release. The vessel must have the diameter of the load sockets in order to allow the connection of the loading hoses. After the arms are connected, they are tested. A board representative will monitor the entire operation, and must be near the cargo outlet of the ship. The terminal will maintain a support team in the Pier with responsibility to attend to any emergency and operational communication between the ship and the terminal.

7.4.3 On-board measurements shall be carried out by the ship's personnel and shall be accompanied by terminal representatives and other inspectors. The material used must be properly grounded and the measuring accessories must be intrinsically safe.

7.4.4 The start of the operation only occurs after the initial letter has been filled out by the Terminal and board representatives. At the initial meeting the emergency stop procedures shall be defined between the ship and the terminal representative (Safety Inspector).

7.4.5 The Ship / Terminal Safety Checklist (Annex I – ISGOTT 6 Security Checklist) is checked and completed by the terminal representative (Safety Inspector) during the initial ship release, when all safety recommendations are addressed.

7.4.6 Boiler tubes should not be soot blown when the tanker is in port. Failure to comply with such regulations shall result in one or more of the following penalties:

- Immediate interruption of operations;
- Fine of the competent authorities;
- Compulsory unloading of the pier ship;
- Notification of infringement to shipowners;
- Liability of the ship for the fines, loss of time and all other related expenses resulting from this fact.

7.4.7 The prohibition on the presence of unauthorized small vessels on the side or near moored vessels should be strictly observed. Only authorized boats by the Terminal may be in the vicinity, provided that they comply with all safety conditions. The transgression of this rule must be reported to the competent authority.

7.4.8 The moored ship will not be able to move its propeller (s) while the hoses remain connected. A ratchet may be used after authorization of the terminal, but the propeller, if moved, must be done slowly, in order to obtain absolute safety. Vessels shall be liable for any damages resulting from such procedures.

7.5 Transferring cargo

7.5.1 The monitoring of the pressures and temperatures during the transfer of the cargo is registered by the representatives: on board and *manifold* of the ship hourly, the Terminal controls the internal pressure variables through the centralized control system. The flow rates on both sides of the operation are withdrawn hourly and compared between the parts, being previously combined a limiting parameter for operational control. Any change in the conditions of operation must be communicated and documented between the parties.

It is expressly forbidden to close valves during operation in order to avoid backpressure in the system.

Communication with the ship must be checked before the start of the operation, never start pumping without the test and perfect communication.

Check all alignment before starting the operation. Track full-line the line of hose connected to the ship and the volume moved at both ends of the duct.

Any defect in critical equipment and accessories that affect the safety or interruption of operation must be reported to the parties and provided for immediate corrective maintenance by the party causing the occurrence.

7.5.2 The ballast nets and tanks of vessels shall only be used for this purpose and shall be isolated from other on-board nets. Ballast water to be discharged into the sea should be completely free of oil, oily residue or other substance capable of causing pollution of seawater; the ballast tanks shall be inspected before the start of the operation at the terminal.

7.5.3 The terminal does not have a system for receive *slop*.

7.5.4 The conventional tank cleaning operation is not generally accepted. However, COW operation may be performed depending on prior scheduling authorization for the ship's stay in port and Terminal Supervisor for operational safety purposes.

7.5.5 No repairs or maintenance work of any nature involving the risk of sparks or other means of ignition may be made while the ship is moored on the Pier. In extreme cases, all safety standards should be observed and met. The Terminal must previously authorize repair that involves the installation of the pier or imply in any restriction of the ship during the stay.

7.5.6 Intermediate inspections, as Annex I - ISGOTT Security Checklist, are performed by the terminal representative (Safety Inspector) during the operation of the ship every 4 hours and recorded the daily service passage.

7.5.7 The interruption of the loading or unloading shall occur in any situation that may present danger to either the ship or the Terminal. Operations may be suspended during storms, lightning strikes, thunderstorms and / or strong winds; limited to or greater than 30 knots to interrupt operation, 35 knots to disconnect the hoses and 40 knots to untie the ship.

The operator of the terminal is authorized to interrupt / suspend the operation in the case of non-compliance with any of the rules and regulations concerning safety, universally accepted and adopted in the maritime transport of oil.

The master of the ship has the right to stop the operation if he has reason to believe that shore operations do not provide security, if he informs the pier operators in advance.

7.5.8 For any emergency, the terminal interrupts ongoing operations so that all actions are geared toward emergency mitigation. The operational response procedures for each type of emergency are described in the terminal PRE.

7.6 Measuring Cargo and Documentation

7.6.1 After the end of the operation, the drainage of the hoses used must be started. Operators will provide drainage for the closed system at the pier. The ship's representative will be in charge of draining the onboard section.

7.6.2 The final shipboard measurements shall be carried out by the ship's personnel and accompanied by the Terminal representatives and other inspectors. The material used must be properly grounded and the measurement accessories must be explosion-proof.

7.6.3 After the end of the operation, the drainage of the loading arms used must be started. Operators will provide drainage for the closed system at the pier. The ship's representative will be in charge of draining the onboard section.

7.7 Unmooring and Departure

7.7.1 During the unmooring maneuver and left the port, it is necessary to observe the limits of the channel and the hazards reported in sub-item 5.3 and its correlates.

7.7.2 The practical one usually disembarks at the same point of shipment as sub-item 5.3.5, where a boat of the harbor practice will await you.

7.8 Compliance with ISPS CODE

The Companhia Docas do Ceará has implemented business security protection measures applicable to ships and control of access to port facilities, in accordance with the requirements of the International Maritime Organization (IMO), by means of ISPS (International Ship and Port Facility) code certification.

In case of need, the Ship through the Port Security Supervisor of the Port Facility Security Officer (PFSO) or through the VHF radio, call channels 16, 10 or 06, may trigger these protection measures.

The Mucuripe Terminal normally operates at security level 01. For further protection details, the ship should contact the Companhia Docas do Ceará Port Facility Security Officer (PFSO), which is qualified in accordance with IMO requirements - taking into account the following numbers: Telephones: (55) 85 3266-8831/8832 - Cel.: (55) 85 98616-8647

7.9 Drug and Alcohol Policy

7.9.1 According ISGOTT 6, item 13.4, for safety and health personnel reasons, the use of drugs and alcohol have dangerous effect on work performance, behavior and unsafety in the work place. Hence, consumption of alcohol or use of illegal drugs at the Transpetro Terminal is not permitted.

7.9.2 The Transpetro to support international authorities efforts to combat illegal drug trafficking and use of alcohol in not permitted place, comply on relevant preventive measures to avoid use, possession, distribution these criminals substances.

8 PORT OR ANCHORAGE ORGANIZATION

8.1 Port Control

8.1.1 The Port of Fortaleza is managed by [Companhia Docas do Ceará] (CDC), whose owner is its Chief Executive Officer, being located at Praça Amigos da Marinha, S / N, Mucuripe - Fortaleza-CE district.

8.1.2 Radio contact can be made for berth on channels 10 or 06 of the Maritime VHF or Telephone: (55) 85 98814-3561.

8.2 Maritime Authority

8.2.1 The Agent of the Maritime Authority in the jurisdiction of CPCE is the Captain of the Ports of the State of Ceará. The headquarters of the Capitania are located at:
Av. Vicente de Castro, 4917 - Mucuripe- Fortaleza - CE - Brazil - CEP: 60180-410
telephone (85) 3133-5100 and email: cpce.secom@marinha.mil.br

8.2.2 All vessels shall carry the required certificates or equivalent documents, within their respective validity periods, in accordance with NPCP-CE.

8.2.3 The boundaries of the port are defined from the entry in DHN 710, and all ships must comply with the port legislation established in the NPCP-CE.

8.2.4 Port State Control and Flag State Control encompasses foreign and national ships that will be subject to Port Inspection by the Port Authority, in accordance with the International Conventions ratified by the Country and norms approved by Ordinance, of the Board of Ports and Coasts.

The arrival (Date-Time) of a vessel, in the anchorage or port area, should be communicated to CPCE as soon as possible by any means available (preferably by email), being obliged to inform CPCE no later than 06 six) hours after the mooring or decking of the vessel.

If in the course of the trip immediately prior to the stopover, any accident or personal incident occurs, with the vessel or the environment, the Captain shall forward to CPCE, preferably by email, a duly authenticated extract of the launch of the occurrence in the Navigation Journal.

8.3 Pilotage

8.3.1 For all maneuvers from the point of embarkation of the Pilot, both Pier and commercial pier, the service of pilotage is mandatory.

8.3.2 The pilot service in the jurisdiction of CPCE (Brazilian Navy) is carried out by the following companies:

a) Ceará Marine Pilots - Company of Practitioners of the State of Ceará Ltda, located at street Osvaldo Cruz, nº 01, room 1901, district of Meireles, Fortaleza-CE, CEP 60125-150, telephone 55 (85) 3388-4640 and on VHF-FM Channels 16 e 10, in permanent listening.

b) Ceará State Pilots - Company of Practitioners of the State of Ceará Ltda, located at street São Paulo, 32, sala 1114, bairro Centro, Fortaleza-CE, CEP 60030-100, telefone 55 (85) 99656-6144.

8.4 Tugboats and other Marine Services

8.4.1 The maneuvers must be made with the different tugboats and boats available in the port; it will be up to the Shipowner or his agent Maritime Agent to order the tugs necessary for the maneuvers to be carried out. On the maneuver, the Captain of the vessel will decide, in agreement with the Practical, the device for the use of the support tugboats, referring to the quantity and its positions to form the necessary torque of force, to guarantee the safety of the berthing.

In tugboat maneuvers near the bows of the ships, the towing rope shall be drawn by means of a catch from the forward casing to the tugboat deck in order to avoid the excessive tug / ship approach, reducing the effects of hydrodynamic interaction between vessels.

List of tugs available at the anchorage and / or at the Terminal, and may be changed to compose the required table at the NPCE, the list of tugs and boats authorized to operate at Mucuripe is updated by the Maritime Authority.

9. EMERGENCY AND COMBAT PLANNING

9.1 Emergency Contacts

Organization	Operating Hours	ID acronym	Telephone	Mobile Phone	Call VHF	Conversation VHF
Port Control	24 h	Docking	X	98814 3561	VHF channel 06/10	VHF channel 06/10
Tugboats	24 h	Tugboats	55 853268-1117 55 853312-2883	55 85 99996 0803 55 85 98122 8903	VHF-channel 16	VHF channel 10
Pilots	24 h	Pilotage	55 853388 4640	55 85 997160001	VHF-channel 16	VHF channel 10
Terminal(Berth) control center	24 h	Transpetro operation	55 853957 0007	X	VHF-channel 06	VHF channel 06
Terminal (Building) Control Center	24 h	Transpetro control	55 853957 0005/ 0006	55 85 99659 2467	VHF-channel 06	VHF channel 06
Police	24 h	CIOPS	190	55 85 3101-6501	nil	nil
Fire Department	24 h		193	55 853101-2373	nil	nil

9.2 Sensitive Areas to the Environment

The Terminal in Fortaleza is located in the Mucuripe and although it is located in, an area not defined as Ecologically Sensitive or Environmental Protection Area (APA). It is close to the anchorage of rafts, Meireles and Iracema beach, areas that are vulnerable to pollution; therefore, it is recommended that all vessels and each seafarer or port user take extra care when loading and unloading, maintenance, cleaning and even operation of equipment that may cause leaks of pollutants pollution of the environment. The leakage of pollutants, whether accidental or not, should be immediately communicated to the Terminal Operator, CPCE and the State Superintendence of the Environment of the State of Ceará (SEMACE) through the telephone number + (55) 85 3101-5520.

9.3 General Description of the Emergency Response Organization

INCIDENTS WITHIN THE MUCURIPE TERMINAL AREA					
Type of Incident	Responsible Organization	Other Organizations Involved			
Collision in the Channel	Port Authority	Civil Defense	TRANSPETRO	Ceará Dock Company	
Ship	Port Authority	Civil Defense	TRANSPETRO	Ceará Dock	

Beaching				Company	
Collision in the Berth	<i>Port Authority</i>	<i>Civil Defense</i>	<i>TRANSPETRO</i>	Ceará Dock Company	
Vessel Sinking	<i>Port Authority</i>	<i>Civil Defense</i>	<i>Fire Department</i>	<i>TRANSPETRO</i>	Ceará Dock Company
Fire in the Vessel	<i>Ship / Cia Docas Ceará</i>	<i>TRANSPETRO</i>	<i>Fire Department</i>	<i>Civil Defense</i>	<i>Port Authority</i>
Fire in the Berth	<i>TRANSPETRO</i>	<i>Fire Department</i>	<i>Civil Defense</i>	<i>Port Authority</i>	Ceará Dock Company
Pollution	<i>TRANSPETRO / Ship</i>	<i>Port Authority</i>	<i>CDA/ Civil Defense</i>	<i>IBAMA</i>	Ceará Dock Company

9.4 Emergency Plan

9.4.1 Terminal - The scope of the Emergency Response Plan (PR), includes the facilities of the Mucuripe Waterway Terminal, with its respective operational activities of oil movement, its derivatives, alcohol and GLPs, within the scope of the Mucuripe Port Industrial Complex - Oil Tanker and Commercial Wharf -, involving Porto, Lubnor, the Distributing Companies and their interconnections (as per plan below).



The actions of combat and control to the emergencies will have priority over the other activities of the Waterway Terminal of Mucuripe, while it lasts the situation.

Any occurrence that has a potential impact on the environment shall be immediately reported to the municipal authorities and to the State and Federal Environmental Audit Bodies.

The actions of combat and neutralization of the effects of the occurrence will be centralized in a single coordination, under the responsibility of the terminal.

The coordination of the emergency response will be carried out by the terminal, in full time and with exclusive dedication until the normalization of the event that generated the emergency.

9.4.2 Ship - During the whole of the terminal mooring period, vessels shall keep on board a contingent of crew members capable of dealing with any emergency situation which may occur. The Vessel shall keep the dock ladder on the opposite side of the dock for use as a secondary escape route ready for evacuation of the crew by boat if necessary.

Comply with the rules for the installation of emergency towing cables, at the on - board and at the overhang - from the bow and stern of the edge opposite the berth - up to the height of the water line throughout the operation.

Emergency and fire-fighting equipment shall be kept ready for use, with the pressurized fire network and operating fire hoses being extended, one forward and one reverse of the outlets while the ship remains moored.

A pollution-fighting kit - consisting of sawdust, rags, shovels, buckets, squeegees, transfer pumps and absorbent barriers - should be kept ready for use in the event of an oil spill. Additional precautions should be taken to avoid oil leakage from seawater pollution.

9.4.3 Medical care –

In case of accident Transpetro has a medical service. It should require provision of relief to the terminal operator that will provide the first aid and / or referral to a specialized hospital.

9.5 Combat and Emergency Public Resources

9.5.1 Port Administrator

The Port Administrator is the same as defined in item 8.1.

9.5.2 Maritime Authority

The Maritime Authority is defined in item 8.2.

9.5.3 Local Emergency Services

In the Port of Mucuripe, the Transpetro, through CRE, has resources that can be used to mitigate pollution accidents. For other emergencies, public organizations offer the support resources, according to the scenario table in item 9.3.

9.5.4 State and National Combatant Organizations

The contracts available to the terminal to combat emergency situations are related in the pre (emergency response plan) accessible in the crisis room of the Mucuripe Terminal.

9.6 Mutual Support Plans

Next to the port facilities are the following industrial and commercial activities, which participate in the PAM Mucuripe:

- Wheat milling facilities - Moinho Dias Branco, Grande Moinho and Fortaleza Mill;
 - Petrobras' naphthenic lubricants plant, called Petrobras - LUBNOR;
 - Storage and distribution park for liquid fuels - Petrobras – BR and Raizen, besides the companies NGB – National Butane Gas and Liquid gas [Nacional Butás Gas and Liguigás].
- In the area of LUBNOR is also installed a UPGN - Natural Gas Processing Unit;
- Warehouses and storage areas of empty containers (Termaco) in the area formerly occupied by Atlantic;
 - Warehouses with loose general cargo, especially of cement (VOTORANTIM), whose movement is done by railroad (receiving) and highway (distribution);
 - Solvents and lubricants industry - PETROLUSA Petróleo e Lubrificantes do Nordeste S/A;
 - Industries of fish, warehouses and offices (along Av. Vicente de Castro);
 - Margarine Factory of M Dias Branco S / A;

9.7 Combating Oil and Chemical Spills

9.7.1 Terminal Combat Capability

The Terminal has an Emergency Response Center (CRE), installed in the Environmental Defense Center (CDA), which is equipped with various equipment and facilities for use in accidental pollution.

When the employee or contractor from the emergency, he / she must report the immediate communication to the Operations Supervision of the Mucuripe Terminal through the telephones listed in item 9.1 or of the radio of the VHF maritime system - Channel 06.

O operador, ao tomar conhecimento da ocorrência, deverá acionar o alarme de emergência e Grupos de Combate.

In emergencies, all local operations should be immediately suspended, taking into account the safety in subsequent actions.

Periodically intensive trainings are carried out, which enable Terminal employees to act according to the scenarios defined in the Emergency Response Plan (PRE). Located in a strategic point, the CRE allows quick action in the fight against emergencies. In its shed are stockpiled containment barriers, oil pickers and other equipment and materials necessary for the scupper. Work vessels and support, are moored at the wharf in permanent state of readiness.

9.7.2 Capacity of Combat of the Environment Organ

The State Secretariat of Environment of Ceará (Semace) does not have resources to combat oil spills in the sea. All actions to combat pollution should be directed to the Mucuripe Waterway Terminal. It is recommended that when listening to the emergency alarm, all workers and visitors should immediately move away from the pier area. Making the work area safe, removing the pier and bridge vehicles other relevant actions. Go to the meeting point at the entrance of the bridge in front of the guardhouse and wait for emergency command instructions.

9.7.3 Resources available in the Mutual Support Plans of other Terminals

The terminal is inserted in the Aid Plan Mutual (PAM) of the Mucuripe Port Complex where the additional resource request may be valued to the participating companies of this Plan. In addition, the terminal can count on additional resources from the other terminals of every country and contract established by the CDA Petrobras.

9.7.4 Combat medium-sized spill

The Mucuripe Terminal has the capacity to combat mid-sized emergency with local resources.

9.7.5 Combat large spill

In large emergency, the Mucuripe terminal has described in its PRE the flow of communication capable of triggering non-regional and national scope resources, therefore, with resources of the other terminals and CDAs, arranged throughout the country.

9.8 Combating Other Large-Scale Emergencies

Transpetro has a special group of contingencies - GEC, if triggered, will provide support for great emergencies. The Terminal lists the actions, those responsible for each predicted event, occur inside terminal, ducts, vessels, and that involves third parties.

For events that are not provided for in this document, Transpetro will make available all national resources that are at your fingertips.

10. CONTACTS

10.1 Transpetro Terminal

Location	Telephone	e-mail	VHF Channel
Control Room	+55 85 3957-0005	operacaomucuripe@transpetro.com.br	06
Terminal Coordinator	+55 85 9 9614-9992	arnildoteixeira@transpetro.com.br
QHSE Manager	+55 85 98129-2521	nadynni.soeiro@transpetro.com.br	----

10.2 Port Services

Organization	Telephone	e-mail	VHF/UHF Channels
Maritime Authority	+55 85 31335106	cpce.secom@marinha.mil.br	16
Port Control	+55 85 98814-3561	acostagem@hotmail.com	06/10
Pilot Station - Atalaia	+55 85 999850293 +55 85 997160001	atalaia@cearapilots.com.br	10/16
Tugboats	+55 91 93343650 +55 85 981228903 +55 85 98168-5673	wellington.leiros@wilsonsons.com.br pedro.veras@saamtowage.com jaqueline.donatti@svitzer.com	10/16

10.3 Navigation Agents

Company	Telephone	e-mail
North Star - Petrobras Agency	+55 85 31141568 +55 85 998500016	fortaleza@nsshopping.com.br
Muniz Agency	+55 85 981050549	operations.for@munizagmar.com.br

10.4 Local Authorities

Organization	Telephone
Police	190
Health Service	192
Fire Department	193

APPENDICES

Annex A – Charter including berths and nearby



Charter 701 - Port of Mucuripe (Fortaleza)

Limits / Boundary

Lg 38 ° 26.80 'W Lt 3 ° 40.0' S Lg 38 ° 33.40 'W Lt 3 ° 44.80' S

Annex B - Aerial photo of the port of Mucuripe (Wharf and Pier)

Annex C Diagram with load connections, dimensions and sizes of the flange's pier and wharfs

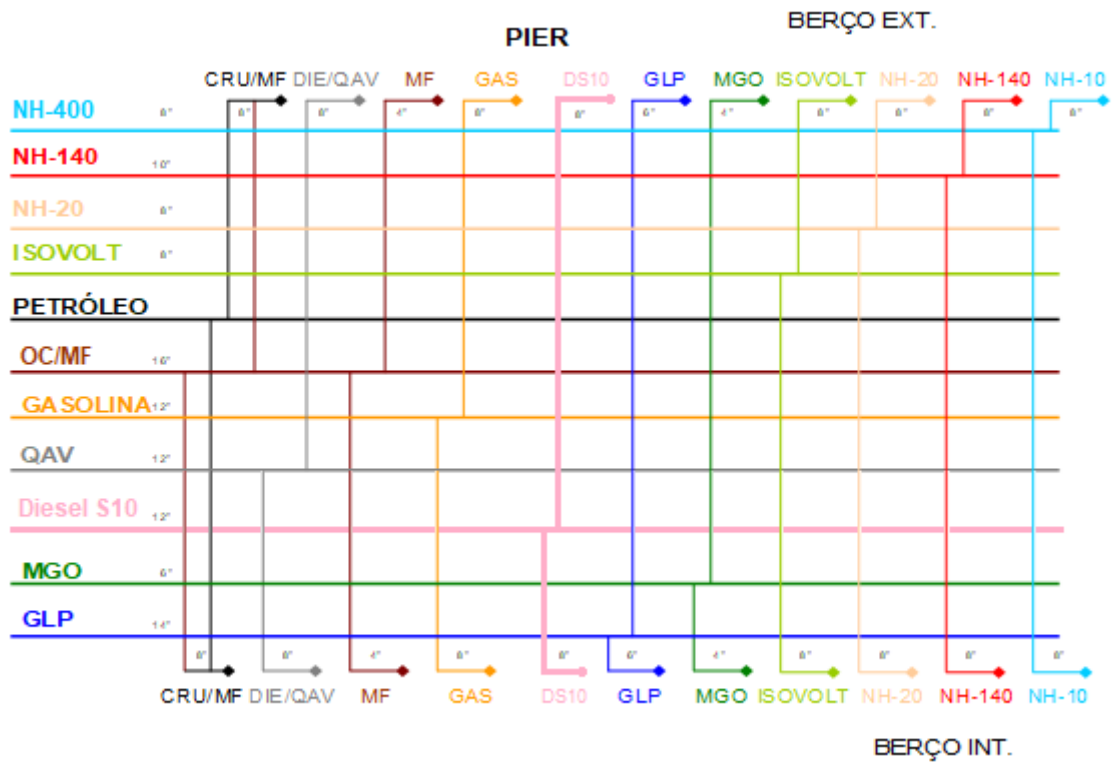

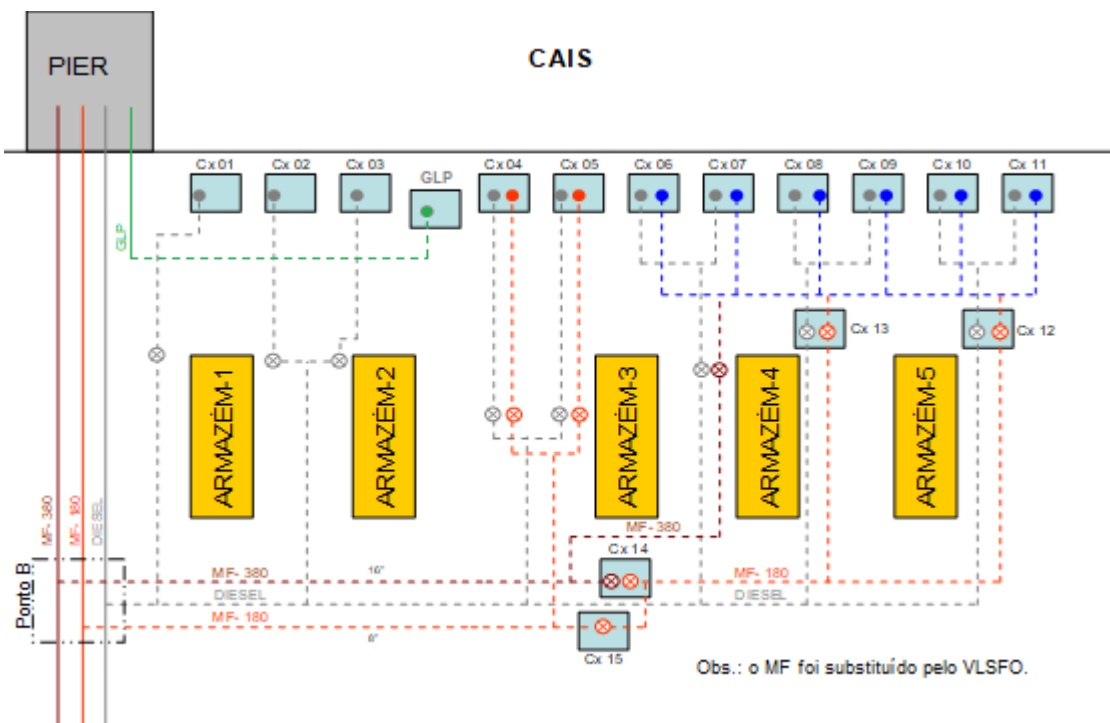
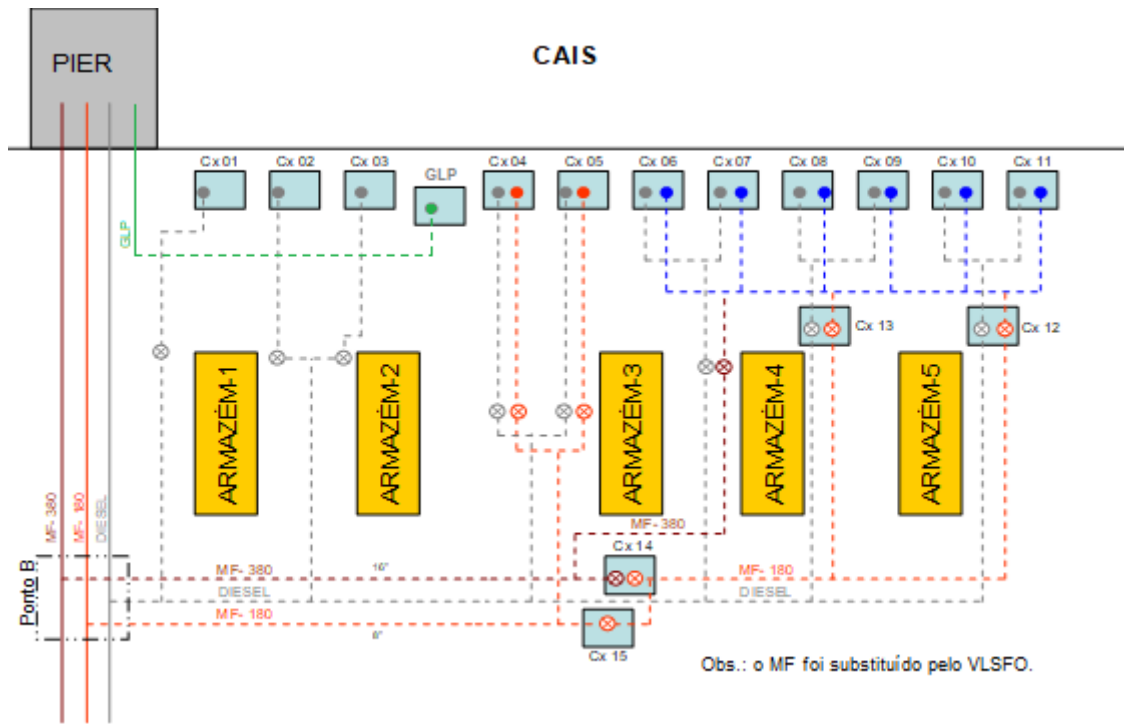

Annex D Essential Vessel Information for the Terminal

PORT AND TERMINAL OF:		
Requesting Information about the Vessel		
Ship's name:	Estimated Arrival Time (ETA):	
Flag:	the last port.	
Master's name	Next Port	
Owners	Agents	
Does the ship have an inert gas system? Oxygen content.		
Total Length	Arrival Departure:	
Length Between Perpendiculars	Maximum Draft During Transfer:	
Mouth	Output Draft:	
Number of engines:	Transverse Propulsion:	Tugs - minimum required:
Number of propellers:	Prow (No. and power)	Static Traction (Bollard Pull)
	Stern (No. and power)	
Number and Size of the Manifold	Distances	
Flanges:	<ul style="list-style-type: none"> • Bow to Manifold • Back to the Manifold • Manifold Height to Main Deck 	
<ul style="list-style-type: none"> • Charging • Ballast • Bunkers 		
LOAD PROGRAMMING (fill in what applies)		
Appointment	Discharge of the ballast into	Slop / ballast discharge to
Type and quantity	the sea:	land:
Type and quantity	Quantity:	Quantity:
Type and quantity	Estimated time:	Estimated time:
DOWNLOAD PROGRAMMING (fill in what applies)		
Type and quantity	Ballast:	
Type and quantity	Volume:	
Type and quantity	Time:	
Provisioned supplies (bunkers)		
Type and quantity	Type and quantity	
Additional information (if any):		

Please fax or email to the Terminal Supervisor,
 Fax No. Email

Annex E Information to be exchanged before load transfer

Information between ship and terminal			
Ship's name:		Mooring berth	
Trip number		Date of mooring:	
CONTRACT DETAILS			
Number of pumps on board:			
volumetric capacity		M3	
Pressure guaranteed at discharge: (When discharge operation)		(kgf/cm ²)	
Simultaneous ballast / discharge capacity with loading / unloading			
Travel information			
Type of charter (VCP, TCP, COA, etc.)			
Type of trip (Cabotage / Long Course)			
Ports or places of origin and destination			
Ship Requested for supply?			
Means of communication between ship and terminal			
Cargo information			
Product:	Quantity:	Temperature:	API
Slop			
Quantity:	Temperature:	API	
Fluidity	Origin:	Contaminants	
Ballast			
Dirty Ballast Amount:		Segregated Ballast Amount:	
Temperature:			
Information on the operation			
For Discharges: Will Ship Special Operation? (COW, Energization, etc.)			
Estimated Time for the operation.			
Time required to stop the pumps			
For Charges: Advance notice time for TOP notice			
Flow for the period of TOP			
Amount of ballast to be discharged			
Maximum allowable flow for debris			
Are there restrictions on electrostatic properties?			
Are there any restrictions on the use of valves with automatic closing?			
Ship / Terminal conditions for loading / unloading operation by product			
Ship Pressure:	MAX Temperature:	Terminal Pressure:	Temperature MAX:
Flow:	Min	Flow:	Min
Sequence of operations by product			
Amount to be charged / discharged			
Tanks of Origin / Destination			
Lines of land / land			
Loading arms / used hoses			
Forecast for start and end of operation			
Further information on operation and safety			

Annex F- Aerial photo with the identifications of the spaces of the port of Mucuripe and adjacencies

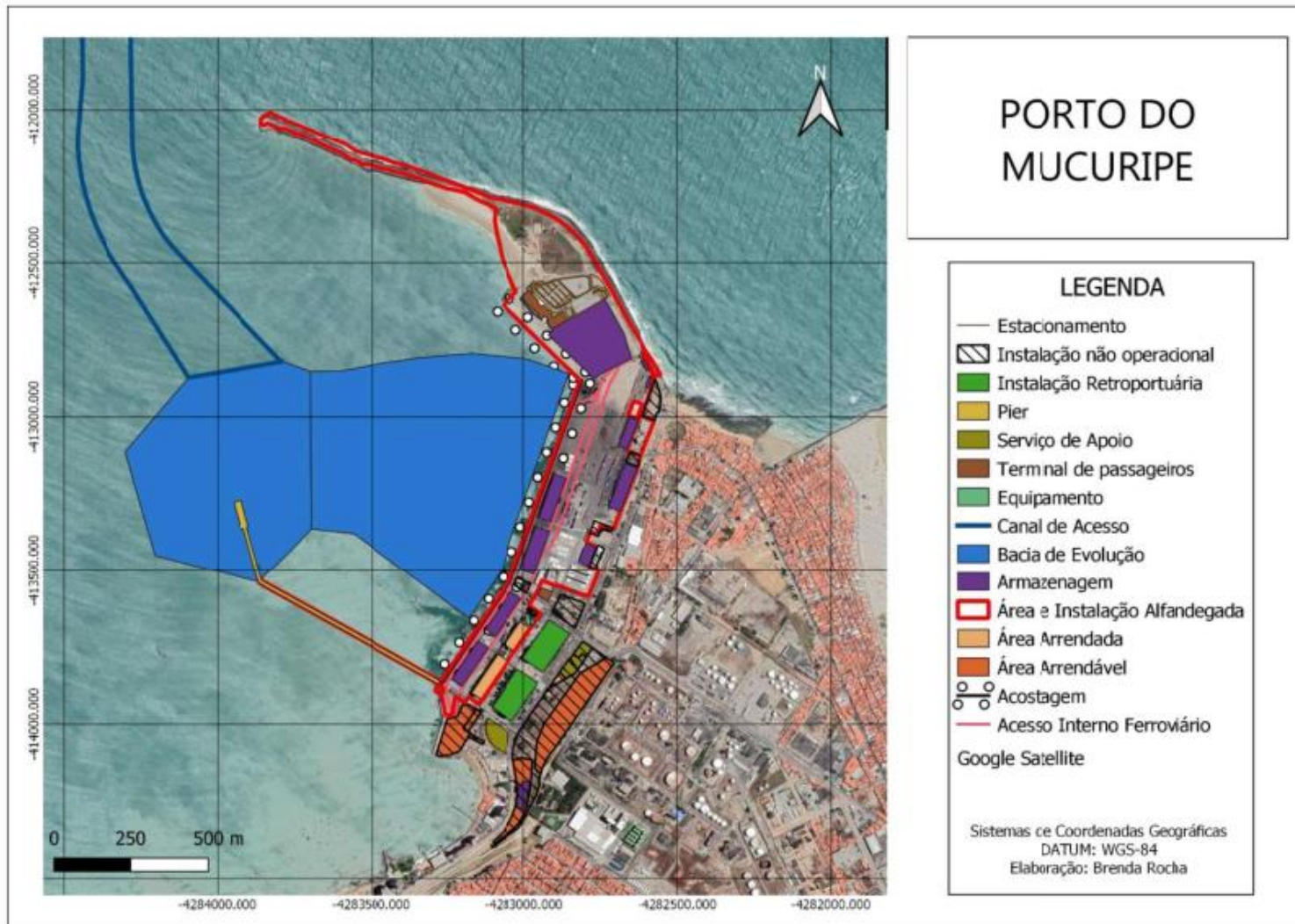

Annex G Mucuripe Harbor Trail Routes

